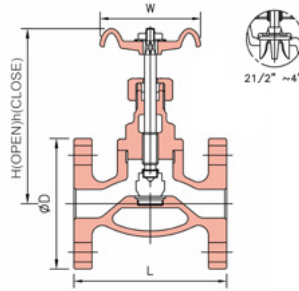

FIG F3B5



序號 NO.	零件	PART	材 質 MATERIAL	
1	閥 體	BODY	CAST BRONZE	
2	閥 蓋	BONNET	CAST BRONZE	
3	閥 門	DISC	1/2"~ 2"	BRASS
			2-1/2"~ 4"	CAST BRONZE
4	閥 桿	STEM	BRASS	
5	迫緊螺帽	PACKING NUT	1/2"~ 2"	BRASS
			2-1/2"~ 4"	CAST BRONZE
6	迫 緊	PACKING	PTFE	
7	格 南	GLAND	1-1/2"~ 4"	BRASS
8	手 輪	HANDWHEEL	ALUMINUM	
9	銘 牌	NAME PLATE	ALUMINUM	
10	手輪螺帽	HANDWHEEL NUT	STEEL	

JIS 5K					JIS 10K				
Working Pressure Non-Shock 最高工作壓力 (靜流水)		Test Pressure (Mpa) Inspection Standard : JIS 2011 試驗壓力 (Mpa)			Working Pressure Non-Shock 最高工作壓力 (靜流水)		Test Pressure (Mpa) Inspection Standard : JIS 2011 試驗壓力 (Mpa)		
Water, Non shock, under 120°C 120°C以下靜流水	0.7 Mpa	Shell Test Pressure 閥體測試壓力	Air 氣壓	Water 水壓	Water, Non shock, under 120°C 120°C以下靜流水	1.4 Mpa	Shell Test Pressure 閥體測試壓力	Air 氣壓	Water 水壓
Oil, Gas, Air or water under 120°C 120°C以下之油, 瓦斯, 空氣或水	0.5 Mpa		0.6 Mpa	1.1 Mpa	Oil, Gas, Air or water under 120°C 120°C以下之油, 瓦斯, 空氣或水	1.0 Mpa		0.6 Mpa	2.1 Mpa
Saturated Steam 飽和蒸汽	0.3 Mpa	Seat Test Pressure 閥座測試壓力 (1/2-4 inch, 15-100mm)	0.6 Mpa		Saturated Steam 飽和蒸汽	1.0 Mpa	Seat Test Pressure 閥座測試壓力 (1/2-4 inch, 15-100mm)	0.6 Mpa	

Features

- Rising Stem
- Screwed Bonnet
- Tapered Plug Type Disc
- PTFE Packing
- Integral Seat

詳細尺寸 Dimension

規格	1/2"	3/4"	1"	1-1/4"	1-1/2"	2"	2-1/2"	3"	4"
Size	15	20	25	32	40	50	65	80	100
L	60	70	80	100	100	120	140	160	175
H	78	88	102	124	135	154	181	227	264
h	72	79	90	104	115	133	154	185	240
φ D(5K)	80	85	95	115	120	130	155	180	200
φ D(10K)	95	100	125	135	140	155	175	185	210
W	55	63	70	70	80	90	110	125	140

單位 Unit: 公釐 mm

FIG 14

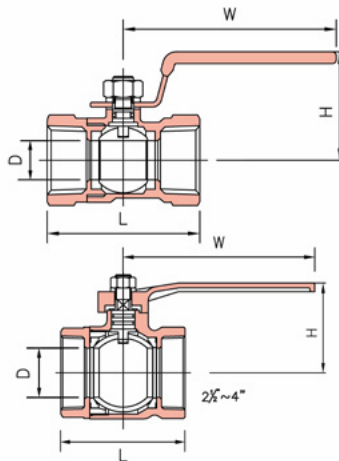

序號 NO.	零件	PART	材 質 MATERIAL	
1	閥 體	BODY	ASTM B62-C83600	
2	閥 蓋	BONNET	ASTM B62-C83600	
3	閥 桿	STEM	ASTM B16-C36000	
4	閥 球	BALL	BRASS(PLATED W/Cr.Ni)/S.S. 304	
5	球 墊	BALL SEAT	PTFE	
6	O 型 環	O-RING	VITON	
			3/8"~ 2"	S.S. 304
7	把 手	LEVER	CAST IRON	
			2-1/2"~ 4"	
8	彈簧華司	SPRING WASHER	S.S. 304	

Features

- 2-Piece Body
- Blowout Proof Stem
- Threaded Ends
- Standard Ports
- Generous PTFE Seats

Working Pressure Non-Shock 最高工作壓力 (靜流水)		Hydrostatic Test Pressure 試驗壓力 (水壓)		
Steam, Working pressure 蒸汽工作壓力	150 psi	Shell Test Pressure 閥體測試壓力	Air 氣壓 80 psi	Water 水壓 900 psi
Water, Oil or Gas 水, 油或氣體	600 psi	Seat Test Pressure 閥座測試壓力	80 psi	660 psi

詳細尺寸 Dimension

規格	3/8"	1/2"	3/4"	1"	1-1/4"	1-1/2"	2"	2-1/2"	3"	4"
Size	10	15	20	25	32	40	50	65	80	100
D	8	10	15	20	25	32	40	50	65	80
L	42	51	59	71	79	91	105	127	148	179
H	36	39	40	45	58	66	80	86	99	120
W	81	82	82	101	133	133	156	195	285	285

單位 Unit: 公釐 mm