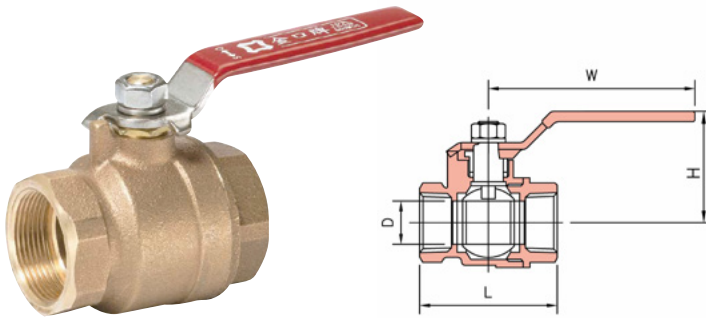

FIG 16



Features

- 2-Piece Body
- Blowout Proof Stem
- Solid brass ball, plated/S.S. 304 Ball
- Threaded Ends
- Full Ports
- Generous PTFE seats and stem packing
- Adjustable stem packing
- MSS Specification SP-110
- CNS-11355 台正字第 5303 號

詳細尺寸 Dimension

單位 Unit: 公釐 mm

| 規格 | 1/4" | 3/8" | 1/2" | 3/4" | 1" | 1-1/4" | 1-1/2" | 2" |
|------|------|------|------|------|-----|--------|--------|-----|
| Size | 8 | 10 | 15 | 20 | 25 | 32 | 40 | 50 |
| D | 10 | 10 | 12.7 | 19 | 25 | 31.8 | 38 | 50 |
| L | 48 | 48 | 51 | 61 | 73 | 84 | 92 | 111 |
| H | 35 | 36 | 38 | 48 | 53 | 63 | 69 | 78 |
| w | 88 | 88 | 88 | 122 | 122 | 134 | 136 | 157 |

| 序號 NO. | 零件 | PART | 材 質 MATERIAL |
|--------|------|---------------|--------------------------------|
| 1 | 閥 體 | BODY | ASTM B62-C83600 |
| 2 | 閥 蓋 | BONNET | ASTM B62-C83600 |
| 3 | 閥 桿 | STEM | ASTM B16-C36000 |
| 4 | 閥 球 | BALL | BRASS(PLATED W/Gr.Ni)/S.S. 304 |
| 5 | 球 墊 | BALL SEAT | PTFE |
| 6 | 格 南 | GLAND | ASTM B16-C36000 |
| 7 | 把 手 | LEVER | S.S. 304 |
| 8 | 彈簧華司 | SPRING WASHER | S.S. 304 |
| 9 | 迫 緊 | PACKING | PTFE |

| Working Pressure Non-Shock 最高工作壓力 (靜流水) | | Hydrostatic Test Pressure 試驗壓力 (水壓) | | |
|--|---------|--|------------------|---------------------|
| Steam Working Pressure 蒸汽工作壓力 | 150 psi | Shell Test Pressure 閥體測試壓力 | Air 氣壓 80 psi | Water 水壓 900 psi |
| Water, Oil or Gas 水, 油或氣體 | 600 psi | Seat Test Pressure 閥座測試壓力 | 80 psi | 660 psi |

FIG 75

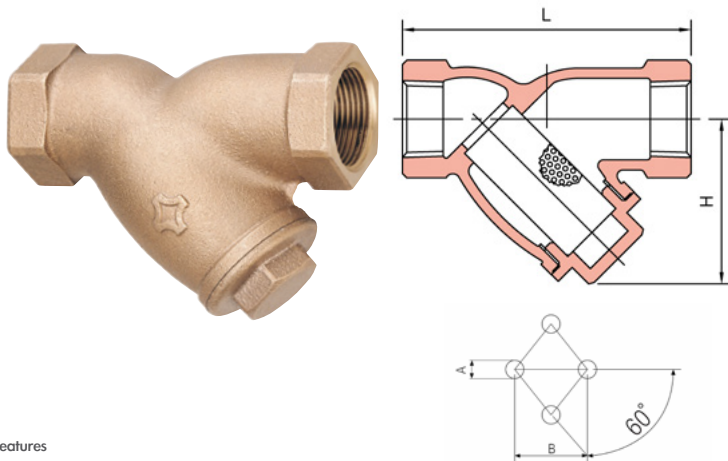

Features

- Y-Pattern Body
- Perforated Stainless Steel Screen
- Screwed Cap
- Threaded Ends

詳細尺寸 Dimension

單位 Unit: 公釐 mm

| 規格 | 3/8" | 1/2" | 3/4" | 1" | 1-1/4" | 1-1/2" | 2 | 2-1/2" | 3" |
|------|------|------|------|-----|--------|--------|-----|--------|-----|
| Size | 10 | 15 | 20 | 25 | 32 | 40 | 50 | 65 | 80 |
| L | 70 | 80 | 100 | 115 | 135 | 160 | 196 | 230 | 239 |
| H | 41 | 48 | 57 | 71 | 81 | 98 | 123 | 147 | 182 |

| 序號 NO. | 零件 | PART | 材 質 MATERIAL |
|--------|-----|--------|-----------------|
| 1 | 閥 體 | BODY | ASTM B62-C83600 |
| 2 | 閥 蓋 | CAP | ASTM B62-C83600 |
| 3 | 墊 片 | GASKET | PTFE |
| 4 | 濾 網 | SCREEN | SUS 304 |

| Working Pressure Non-Shock 最高工作壓力 (靜流水) | | Hydrostatic Test Pressure 試驗壓力 (水壓) | | |
|--|---------|--|------------------|---------------------|
| Steam, Water, Oil or Gas 蒸汽, 水, 油或氣體 | 150 psi | Shell Test Pressure 閥體測試壓力 | Air 氣壓 80 psi | Water 水壓 450 psi |
| Cold Working Pressure 常溫工作壓力 | 300 psi | | | |

| 規格 | A | B |
|---------|-----|-----|
| 3/8"~3" | 1.5 | 2.5 |