

600 WOG

鍛造黃銅球塞閥(全量型)

Forge Brass Ball Valve  
(Full ports)

FIG 11

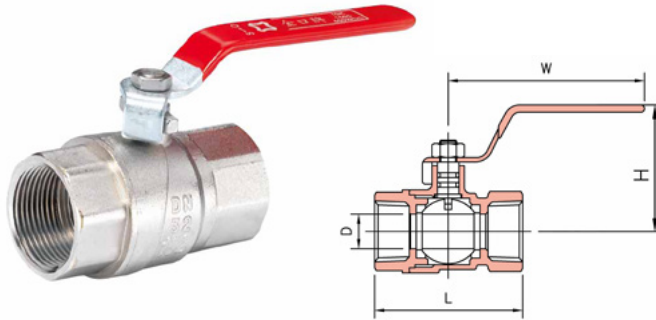

Features

- 2-Piece Body
- Full Ports
- Blowout Proof Stem
- Generous PTFE Seats
- Solid brass ball, plated
- MSS Specification SP-110
- Threaded Ends

序號 NO.	零件	PART	材 質 MATERIAL
1	閥 體	BODY	FORGE BRASS(PLATE W/Ni)
2	閥 蓋	BONNET	FORGE BRASS(PLATE W/Ni)
3	閥 球	BALL	BRASS PLATE (W/Cr)
4	閥 桿	STEM	BRASS PLATE (W/Cr)
5	球 墊	BALL SEAT	PTFE
6	把 手	LEVER	STEEL W/PLASTIC COATED
7	螺 帽	NUT	STEEL
8	O 型 環	O-RING	NBR

Working Pressure Non-Shock 最高工作壓力 (靜流水)		Hydrostatic Test Pressure 試驗壓力 (水壓)		
Steam, Water, Oil or Gas 蒸汽 · 水 · 油或氣體	150 psi	Shell Test Pressure 閥體測試壓力	Air 氣壓 80 psi	Water 水壓 900 psi
Water, Oil or Gas 水, 油或氣體	600 psi	Seat Test Pressure 閥座測試壓力	80 psi	660 psi

詳細尺寸 Dimension

單位 Unit: 公釐 mm

規格	3/8"	1/2"	3/4"	1"	1-1/4"	1-1/2"	2"	2-1/2"	3"	4"
Size	10	15	20	25	32	40	50	65	80	100
D	10	15	20	25	32	40	50	65	80	100
H	42	43	47	56	64	80	87	123	128	148
L	51	57	66	80	94	103	126	133	145	179
W	85	95	96	109	131	151	170	225	275	295

600 WOG

黃銅球塞閥

Brass Ball Valve

FIG 12

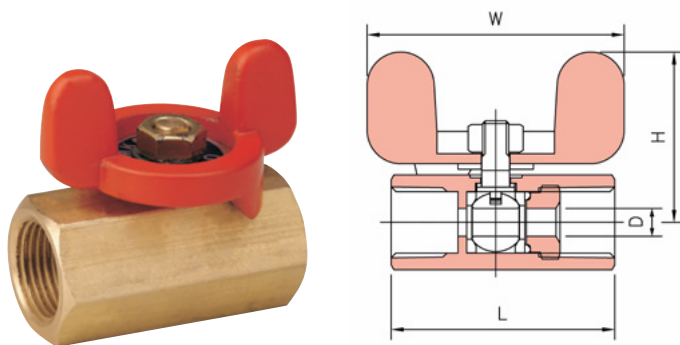

Features

- 1-Piece Body
- Reduce Ports
- Blowout Proof Stem
- Generous PTFE Seats
- Solid brass ball, plated
- Threaded Ends

序號 NO.	零件	PART	材 質 MATERIAL
1	閥 體	BODY	ASTM B16-C36000
2	閥 蓋	BONNET	ASTM B16-C36000
3	閥 球	BALL	BRASS (PLATE W/Cr.Ni)
4	閥 桿	STEM	ASTM B16-C36000
5	球 墊	BALL SEAT	PTFE
6	手 輪	HANDWHEEL	ALUMINIUM
7	銘 牌	NAME PLATE	ALUMINIUM

Working Pressure Non-Shock 最高工作壓力 (靜流水)		Hydrostatic Test Pressure 試驗壓力 (水壓)		
Steam, Working Pressure 蒸汽工作壓力	150 psi	Shell Test Pressure 閥體測試壓力	Air 氣壓 80 psi	Water 水壓 900 psi
Water, Oil or Gas 水, 油或氣體	600 psi	Seat Test Pressure 閥座測試壓力	80 psi	660 psi

詳細尺寸 Dimension

單位 Unit: 公釐 mm

規格	1/4"	3/8"	1/2"	3/4"
Size	8	10	15	20
D	5	8	10	12.5
H	33	74	76	84
L	40	44	54	60
W	46	46	46	49