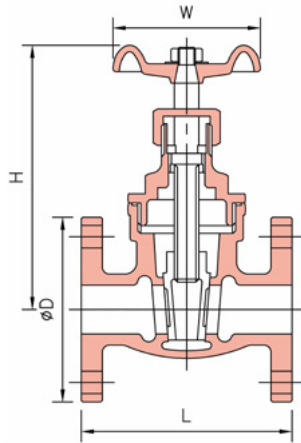

FIG F44B



Features

- Non-Rising Stem
- PTFE Packing
- Screwed Bonnet
- Integral Bronze Seat
- Solid Wedge Disc
- Flanged Ends are plain faced with two V-shaped concentric grooves between the port and bolt holes.
- Full Ports

序號 NO.	零件	PART	材 質 MATERIAL
1	閥 體	BODY	CAST BRONZE
2	閥 蓋	BONNET	CAST BRONZE
3	閥 門	DISC	CAST BRONZE
4	閥 桿	STEM	BRASS
5	迫緊螺帽	PACKING NUT	BRASS
6	迫 緊	PACKING	PTFE
7	格 南	GLAND	1-1/2"~4" BRASS
8	手 輪	HANDWHEEL	ALUMINUM
9	銘 牌	NAME PLATE	ALUMINUM
10	螺 帽	HANDWHEEL NUT	STEEL

Working pressure Non-Shock 最高工作壓力 (靜流水)	Test Pressure (Mpa) Inspection Standard : JIS 2011 試驗壓力 (Mpa)	閥體測試壓力		
		Shell Test Pressure	Air 氣壓	Water 水壓
Water, Non shock, under 120°C 120°C以下靜流水	1.4 Mpa		0.6 Mpa	2.1 Mpa
Oil, Gas, Air or water under 120°C 120°C以下之油, 瓦斯, 空氣或水	1.0 Mpa		0.6 Mpa	2.1 Mpa
Saturated Steam 飽和蒸汽	1.0 Mpa	Seat Test Pressure 閥座測試壓力 (1/2-4 inch, 15-100mm)	0.6 Mpa	

詳細尺寸 Dimension

規格	1/2"	3/4"	1"	1-1/4"	1-1/2"	2"	2-1/2"	3"	4"
Size	15	20	25	32	40	50	65	80	100
L	80	80	80	100	100	115	128	150	165
H	104	104	104	116	123	184	200	216	258
Ø D	95	100	125	135	140	155	175	185	210
W	63	63	63	70	80	90	110	125	140

單位 Unit: 公釐 mm

FIG F4B5

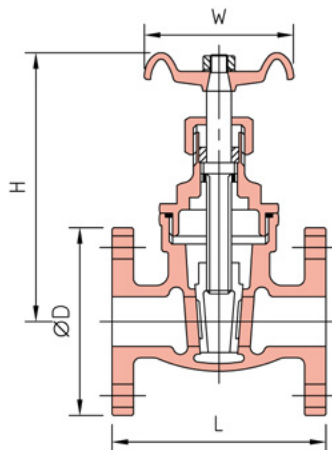

Features

- Non-Rising Stem
- PTFE Packing
- Screwed Bonnet
- Integral Bronze Seat
- Solid Wedge Disc
- Flanged Ends are plain faced with two V-shaped concentric grooves between the port and bolt holes.
- Full Ports

序號 NO.	零件	PART	材 質 MATERIAL
1	閥 體	BODY	CAST BRONZE
2	閥 蓋	BONNET	CAST BRONZE
3	閥 門	DISC	CAST BRONZE
4	閥 桿	STEM	BRASS
5	迫緊螺帽	PACKING NUT	BRASS
6	迫 緊	PACKING	PTFE
7	格 南	GLAND	1-1/2"~4" BRASS
8	手 輪	HANDWHEEL	ALUMINUM
9	銘 牌	NAME PLATE	ALUMINUM
10	螺 帽	HANDWHEEL NUT	STEEL

Working Pressure Non-Shock 最高工作壓力 (靜流水)	Test Pressure (Mpa) Inspection Standard : JIS 2011 試驗壓力 (Mpa)	閥體測試壓力		
		Shell Test Pressure	Air 氣壓	Water 水壓
Water, Non shock, under 120°C 120°C以下靜流水	0.7 Mpa		0.6 Mpa	1.1 Mpa
Oil, Gas, Air or water under 120°C 120°C以下之油, 瓦斯, 空氣或水	0.5 Mpa		0.6 Mpa	1.1 Mpa
Saturated Steam 飽和蒸汽	0.3 Mpa	Seat Test Pressure 閥座測試壓力 (1/2-4 inch, 15-100mm)	0.6 Mpa	

詳細尺寸 Dimension

規格	1/2"	3/4"	1"	1-1/4"	1-1/2"	2"	2-1/2"	3"	4"
Size	15	20	25	32	40	50	65	80	100
L	80	80	80	100	100	115	128	142	165
H	95	95	108	118	133	157	198	220	272
Ø D	80	85	95	115	120	130	155	180	200
W	63	63	63	70	80	90	110	125	140

單位 Unit: 公釐 mm