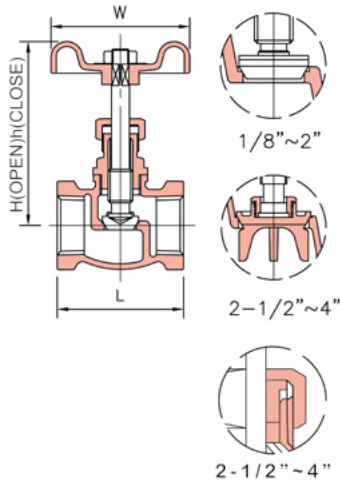

FIG 33



Features

- Rising Stem
- PTFE Packing
- Screwed Bonnet
- Integral Seat
- Tapered Plug Type Disc
- MSS Specification SP-80 Type 1
- Threaded Ends

序號 NO.	零件	PART	材 質 MATERIAL	
1	閥 體	BODY	ASTM B62-C83600	
2	閥 蓋	BONNET	ASTM B62-C83600	
3	閥 門	DISC	1/8"~2"	ASTM B16-C36000
			2-1/2"~4"	ASTM B62-C83600
4	閥 桿	STEM	ASTM B16-C36000	
5	迫緊螺帽	PACKING NUT	1/8"~2"	ASTM B16-C36000
			2-1/2"~4"	ASTM B62-C83600
6	迫 緊	PACKING	PTFE	
7	手 輪	HANDWHEEL	ALUMINIUM	
8	銘 牌	NAME PLATE	ALUMINIUM	
9	螺 帽	HANDWHEEL NUT	STEEL	
10	格 南	GLAND	1-1/2"~4" ASTM B16-C36000	

Working Pressure Non-Shock 最高工作壓力 (靜流水)		Hydrostatic Test Pressure 試驗壓力 (水壓)		
Steam,Water,Oil or Gas 蒸汽 . 水 . 油或氣體	125 psi	Shell Test Pressure 閥體測試壓力	Air 氣壓	Water 水壓
			80 psi	300 psi
Cold Working Pressure 常溫工作壓力	200 psi	Seat Test Pressure 閥座測試壓力	80 psi	200 psi

詳細尺寸 Dimension

單位 Unit: 公釐 mm

規格	1/8"	1/4"	3/8"	1/2"	3/4"	1"	1-1/4"	1-1/2"	2"	2-1/2"	3"	4"
Size	6	8	10	15	20	25	32	40	50	65	80	100
L	45	45	45	48	56	65	74	84	100	119	136	170
H	79	79	79	81	89	104	121	132	154	185	223	261
h	71	73	73	73	80	92	103	116	138	155	190	225
W	55	55	55	55	63	70	70	80	90	110	125	140

FIG 35

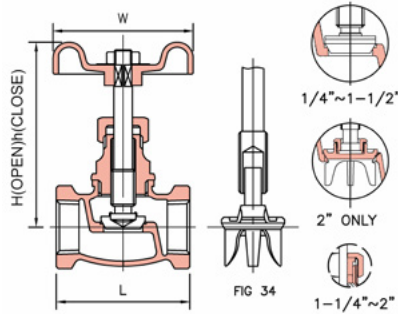

Features

- Rising Stem
- Full Ports
- Screwed Bonnet
- PTFE Packing
- Tapered Plug Type Disc
- Integral Seat
- SDNR Disc Fig.34
- MSS Specification SP-80 Type 1
- Threaded Ends

序號 NO.	零件	PART	材 質 MATERIAL	
1	閥 體	BODY	ASTM B62-C83600	
2	閥 蓋	BONNET	ASTM B62-C83600	
3	閥 門	DISC	1/4"~ 1-1/2"	ASTM B16-C36000
			2"	ASTM B62-C83600
4	閥 桿	STEM	ASTM B16-C36000	
5	迫緊螺帽	PACKING NUT	1/4"~ 1-1/2"	ASTM B16-C36000
			2"	ASTM B62-C83600
6	迫 緊	PACKING	PTFE	
7	手 輪	HANDWHEEL	ALUMINIUM	
8	銘 牌	NAME PLATE	ALUMINIUM	
9	螺 帽	HANDWHEEL NUT	STEEL	
10	格 南	GLAND	1-1/4"~2" ASTM B16-C36000	

Working Pressure Non-Shock 最高工作壓力 (靜流水)		Hydrostatic Test Pressure 試驗壓力 (水壓)		
Steam,Water,Oil or Gas 蒸汽 . 水 . 油或氣體	150 psi	Shell Test Pressure 閥體測試壓力	Air 氣壓	Water 水壓
			80 psi	450 psi
Cold Working Pressure 常溫工作壓力	300 psi	Seat Test Pressure	80 psi	300 psi

詳細尺寸 Dimension

單位 Unit: 公釐 mm

規格	1/4"	3/8"	1/2"	3/4"	1"	1-1/4"	1-1/2"	2"
Size	8	10	15	20	25	32	40	50
L	45	45	53	65	77	85	100	119
H	77	79	86	100	117	121	151	177
h	73	73	80	92	106	115	135	158
W	55	55	63	70	70	80	90	110